

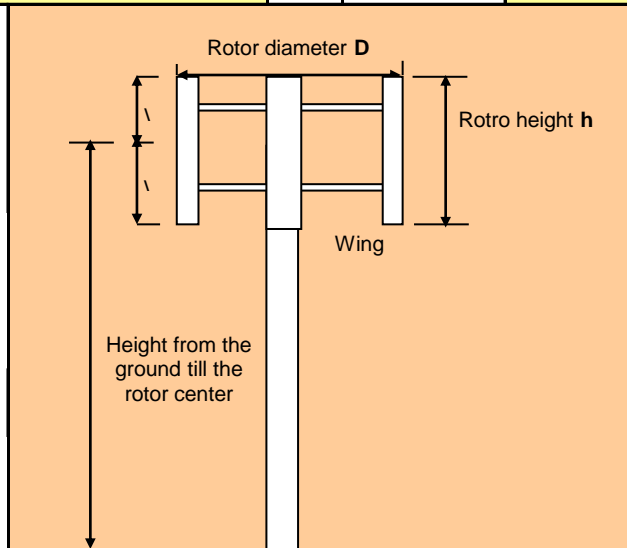

Features Ropatec's small wind turbine vertical axis

Manufacturer		ROPATEC		data AEP	
Model		MINI VERTICAL		Power curve	
		1		Wind speed (m/s)	Power (W)
Number of installed turbines, in how many countries		800 turbines in 34 countries		1	
Nominal power (KVA)		750W		2	
Wind speed (m/s)	Cut-in	2-3m/s		3	3
	Nominal	14		4	8
	Cut-out	/		5	19
	Wind class IEC61400	class 3 (peaks of 53m/s)		6	37
Axis		Vertical axis		7	65
Pale aerogeneratore	Number	3		8	102
	Material	iron, aluminium and fiberglass		9	155
Rotore diameter D (m)		1,5m		10	226
Rotor height h (m), for vertical axis wind turbines		1,5m		11	317
Autonomus start up		ca. 3m/s		12	433
Controlled power output		Power curve, mppt system		13	576
Rotation velocity (rpm)	Minimum	1		14	750
	Nominal	180		15	966
	Maximum	/		16	1068
Gearbox		absent		17	1140
Generator type		PMG - permanent magnet generator		18	1211
Noise level	Level (dBA)	ca. 43dB		19	
	At which wind speed (m/s)	10m/s		20	
	Distance from the generator (m)	20m		21	
Wind turbine support	Height H center from foundation (m)	Lowest	10,55m	Possible AEP	
		Usual	10,55m	Speed (m/s)	5,5
		Max	10,55m	Factor K	2
	Type	Self carrying structure	self carrying	kWh/year	560
Lattice tower		on request	Speed (m/s)	6	
Weights	Turbine (without mast)	150kg		Factor K	2
	Weight of the carrying structure	385kg/10,9m		kWh/year	720
Platform		is needed		Speed (m/s)	7
Installation area		Urban / suburban		Factor K	2
Lifetime (years)		25 anni		kWh/year	1060
Installation manual language		English			



All data are subject to change without notice.



Features Ropatec's small wind turbine vertical axis

Manufacturer		ROPATEC		data AEP	
Model		MAXI VISION		Power curve	
		1		Wind speed (m/s)	Power (W)
Number of installed turbines, in how many countries		800 turbines in 34 countries		1	
Nominal power (KVA)		3KVA		2	
Wind speed (m/s)	Cut-in	2-3m/s		3	11
	Nominal	14		4	29
	Cut-out	/		5	70
	Wind class IEC61400	class 3 (peaks of 53m/s)		6	136
Axis		Vertical axis		7	235
Pale aerogeneratore	Number	3		8	371
	Material	iron, aluminium and fiberglass		9	561
Rotore diameter D (m)		3,3m		10	821
Rotor height h (m), for vertical axis wind turbines		2,2m		11	1151
Autonomus start up		ca. 3m/s		12	1572
Controlled power output		Power curve, mppt system		13	2091
Rotation velocity (rpm)	Minimum	1		14	2722
	Nominal	120		15	3600
	Maximum	/		16	3600
Gearbox		absent		17	3600
Generator type		PMG - permanent magnet generator		18	3600
Noise level	Level (dBA)	ca. 43dB		19	
	At which wind speed (m/s)	10m/s		20	
	Distance from the generator (m)	20m		21	
Wind turbine support	Height H center from foundation (m)	Lowest	11,79m	Possible AEP	
		Usual	11,79m	Speed (m/s)	5,5
		Max	11,79m	Factor K	2
	Tipe	Self carrying structure	self carrying	kWh/year	2100
Lattice tower		on request	Speed (m/s)	6	
Weights	Turbine (without mast)		620kg	Factor K	2
	Weight of the carrying structure		755kg/10,9m	kWh/year	2.800
	Platform		is needed	Speed (m/s)	7
Installation area		Urban / suburban		Factor K	2
Lifetime (years)		25 anni		kWh/year	4.500
Installation manual language		English			

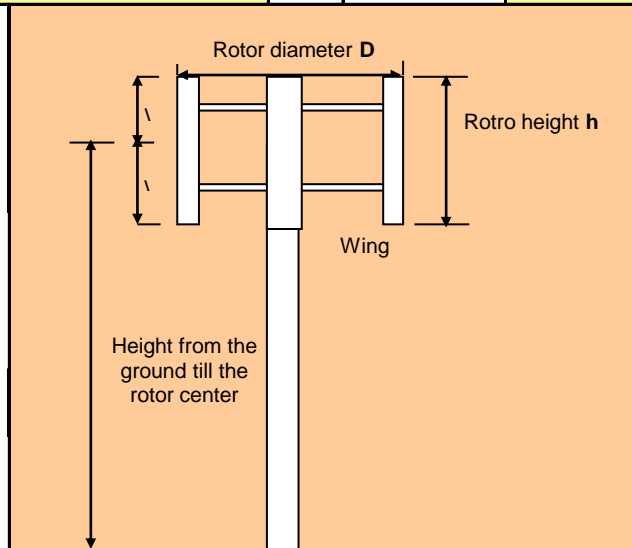

All data are subject to change without notice.



Features Ropatec's small wind turbine vertical axis

Manufacturer		ROPATEC		data AEP	
Model		EASY VERTICAL HE		Power curve	
		1		Wind speed (m/s)	Power (W)
Number of installed turbines, in how many countries		800 turbines in 34 countries		1	
Nominal power (KVA)		1KW		2	
Wind speed (m/s)	Cut-in	3-4m/s		3	0
	Nominal	12		4	27
	Cut-out	/		5	53
	Wind class IEC61400	class 3 (peaks of 53m/s)		6	91
Axis		Vertical axis		7	144
Pale aerogeneratore	Number	3		8	217
	Material	iron, aluminium and fiberglass		9	318
Rotore diameter D (m)		1,9m		10	447
Rotor height h (m), for vertical axis wind turbines		1,8m		11	610
Autonomus start up		ca. 3m/s		12	911
Controlled power output		Power curve, mppt system		13	1155
Rotation velocity (rpm)	Minimum	1		14	1200
	Nominal	240		15	1200
	Maximum	/		16	1200
Gearbox		absent		17	1200
Generator type		PMG - permanent magnet generator		18	1200
Noise level	Level (dBA)	ca. 43dB		19	
	At which wind speed (m/s)	10m/s		20	
	Distance from the generator (m)	20m		21	
Wind turbine support	Height H center from foundation (m)	Lowest	10,80m	Possible AEP	
		Usual	10,80m	Speed (m/s)	5,5
		Max	10,80m	Factor K	2
	Type	Self carrying structure	self carrying	kWh/year	1.180
Lattice tower		on request	Speed (m/s)	6	
Weights	Turbine (without mast)	145kg		Factor K	2
	Weight of the carrying structure	385kg/10,9m		kWh/year	1.500
Platform		is needed		Speed (m/s)	7
Installation area		Urban / suburban		Factor K	2
Lifetime (years)		25 anni		kWh/year	2.200
Installation manual language		English			

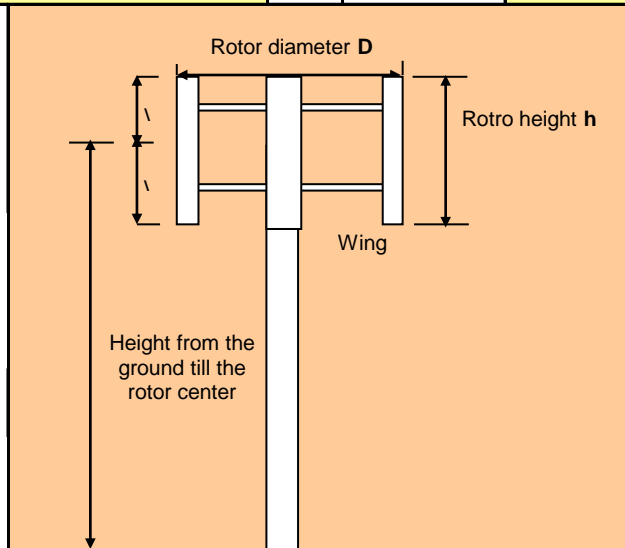

All data are subject to change without notice.



Features Ropatec's small wind turbine vertical axis

Manufacturer		ROPATEC		data AEP			
Model		SIMPLY VERTICAL		Power curve			
		1		Wind speed (m/s)	Power (W)		
Number of installed turbines, in how many countries		800 turbines in 34 countries		1			
Nominal power (KVA)		3KW		2			
Wind speed (m/s)	Cut-in	3-4m/s		3	22		
	Nominal	14		4	64		
	Cut-out	18		5	127		
	Wind class IEC61400	class 3 (peaks of 53m/s)		6	224		
Axis		Vertical axis		7	362		
Pale aerogeneratore	Number	3		8	551		
	Material	iron, aluminium and fiberglass		9	799		
Rotore diameter D (m)		3,3m		10	1117		
Rotor height h (m), for vertical axis wind turbines		2m		11	1497		
Autonomus start up		ca. 3m/s		12	1957		
Controlled power output		Power curve, mppt system		13	2506		
Rotation velocity (rpm)	Minimum	1		14	3152		
	Nominal	144		15	3600		
	Maximum	216		16	3600		
Gearbox		absent		17	3600		
Generator type		PMG - permanent magnet generator		18	3600		
Noise level	Level (dBA)		ca. 43dB	19			
	At which wind speed (m/s)		10m/s	20			
	Distance from the generator (m)		20m	21			
Wind turbine support	Height H center from foundation (m)	Lowest	11,74m	Possible AEP			
		Usual	11,74m				
		Max	11,74m				
	Tipe	Self carrying structure	self carrying				
Lattice tower		on request					
Weights	Turbine (without mast)		620kg			Speed (m/s)	5,5
	Weight of the carrying structure		755kg/10,9m			Factor K	2
Platform		is needed				kWh/year	3300
Installation area		Urban / suburban				Speed (m/s)	6
Lifetime (years)		25 anni				Factor K	2
Installation manual language		English		kWh/year	4200		

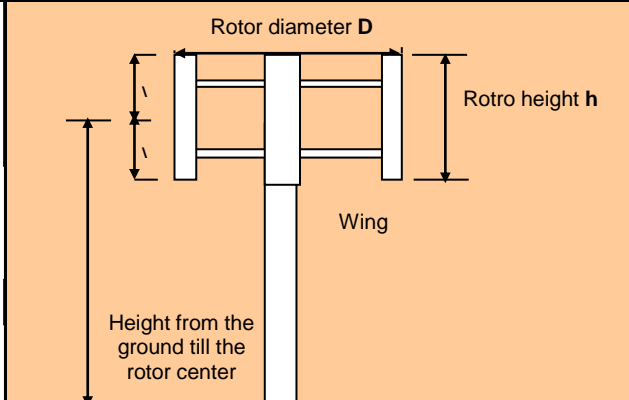

All data are subject to change without notice.



Features Ropatec's small wind turbine vertical axis

Manufacturer		ROPATEC		data AEP	
Model		SIMPLY VERTICAL HE		Power curve	
		1		Wind speed (m/s)	Power (W)
Number of installed turbines, in how many countries		800 turbines in 34 countries		1	
Nominal power (KVA)		3KW		2	
Wind speed (m/s)	Cut-in	3-4m/s		3	33
	Nominal	14		4	96
	Cut-out	18		5	191
	Wind class IEC61400	class 3 (peaks of 53m/s)		6	336
Axis		Vertical axis		7	543
Pale aerogeneratore	Number	3		8	827
	Material	iron, aluminium and fiberglass		9	1199
Rotore diameter D (m)		3,3m		10	1676
Rotor height h (m), for vertical axis wind turbines		3m		11	2246
Autonomus start up		ca. 3m/s		12	2936
Controlled power output		Power curve, mppt system		13	3600
Rotation velocity (rpm)	Minimum	1		14	3600
	Nominal	138		15	3600
	Maximum	190		16	3600
Gearbox		absent		17	3600
Generator type		PMG - permanent magnet generator		18	3600
Noise level	Level (dBA)		ca. 43dB	19	
	At which wind speed (m/s)		10m/s	20	
	Distance from the generator (m)		20m	21	
Wind turbine support	Height H center from foundation (m)	Lowest	12,24m	Possible AEP	
		Usual	12,24m	Speed (m/s)	5,5
		Max	12,24m	Factor K	2
	Tipe	Self carrying structure	self carrying	kWh/year	4200
Lattice tower		on request	Speed (m/s)	6	
Weights	Turbine (without mast)		660kg	Factor K	2
	Weight of the carrying structure		755kg/10,9m	kWh/year	5400
Platform		is needed		Speed (m/s)	7
Installation area		Urban / suburban		Factor K	2
Lifetime (years)		25 anni		kWh/year	8100
Installation manual language		English			

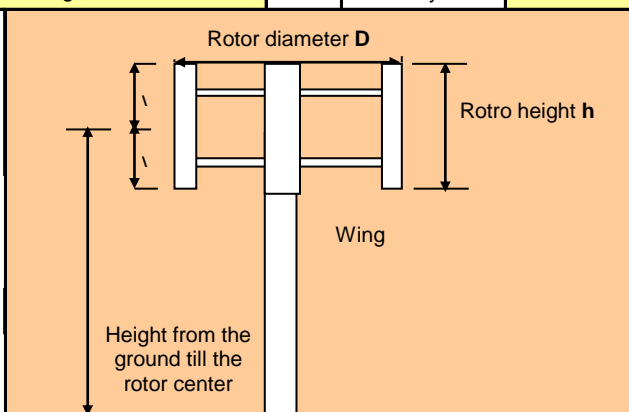

All data are subject to change without notice.



Features Ropatec's small wind turbine vertical axis

Manufacturer		ROPATEC		data AEP	
Model		MAXI VERTICAL		Power curve	
		1		Wind speed (m/s)	Power (W)
Number of installed turbines, in how many countries		800 turbines in 34 countries		1	
Nominal power (KVA)		6KW		2	
Wind speed (m/s)	Cut-in	3-4m/s		3	46
	Nominal	14		4	112
	Cut-out	18		5	224
	Wind class IEC61400	class 3 (peaks of 53m/s)		6	394
Axis		Vertical axis		7	638
Pale aerogeneratore	Number	3		8	970
	Material	iron, aluminium and fiberglass		9	1407
Rotore diameter D (m)		4,7m		10	1965
Rotor height h (m), for vertical axis wind turbines		2,5m		11	2634
Autonomus start up		ca. 3m/s		12	3445
Controlled power output		Power curve, mppt system		13	4410
Rotation velocity (rpm)	Minimum	1		14	5547
	Nominal	100		15	6000
	Maximum	155		16	6000
Gearbox		absent		17	6000
Generator type		PMG - permanent magnet generator		18	6000
Noise level	Level (dBA)	ca. 43dB		19	
	At which wind speed (m/s)	10m/s		20	
	Distance from the generator (m)	20m		21	
Wind turbine support	Height H center from foundation (m)	Lowest	11,84m	Possible AEP	
		Usual	11,84m	Speed (m/s)	5,5
		Max	11,84m	Factor K	2
	Type	Self carrying structure	self carrying	kWh/year	5900
Lattice tower		on request	Speed (m/s)	6	
Weights	Turbine (without mast)		960kg	Factor K	2
	Weight of the carrying structure		792kg/10,9m	kWh/year	7500
	Platform		is needed	Speed (m/s)	7
Installation area		Urban / suburban		Factor K	2
Lifetime (years)		25 anni		kWh/year	10800
Installation manual language		English			

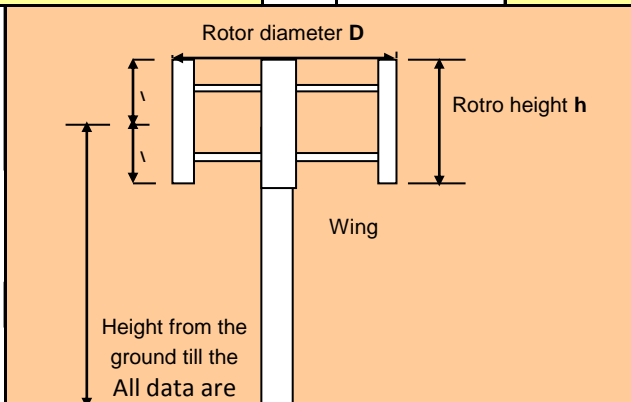

All data are subject to change without notice.



Features Ropatec's small wind turbine vertical axis

Manufacturer		ROPATEC		data AEP	
Model		BIG STAR		Power curve	
		1		Wind speed (m/s)	Power (W)
Number of installed turbines, in how many countries		800 turbines in 34 countries		1	
Nominal power (KVA)		20KW		2	
Wind speed (m/s)	Cut-in	3-4m/s		3	102
	Nominal	14		4	241
	Cut-out	18		5	500
	Wind class IEC61400	class 3 (peaks of 53m/s)		6	1005
Axis		Vertical axis		7	1734
Pale aerogeneratore	Number	3		8	2796
	Material	iron and fiberglass		9	4276
Rotore diameter D (m)		8m		10	6068
Rotor height h (m), for vertical axis wind turbines		4,3		11	8346
Autonomus start up		ca. 3m/s		12	11360
Controlled power output		Power curve, mppt system		13	14894
Rotation velocity (rpm)	Minimum	1		14	19166
	Nominal	60		15	19990
	Maximum	90		16	19990
Gearbox		absent		17	19990
Generator type		PMG - permanent magnet generator		18	19990
Noise level	Level (dBA)		ca. 43dB	19	
	At which wind speed (m/s)		10m/s	20	
	Distance from the generator (m)		20m	21	
Wind turbine support	Height H center from foundation (m)	Lowest	19,53m	Possible AEP	
		Usual	19,53m	Speed (m/s)	5,5
		Max	19,53m	Factor K	2
	Tipe	Self carrying structure	self carrying	kWh/year	23700
Lattice tower		on request	Speed (m/s)	6	
Weights	Turbine (without mast)		3500kg	Factor K	2
	Weight of the carrying structure		3150kg/18m	kWh/year	30000
Platform		is needed		Speed (m/s)	7
Installation area		Urban / suburban		Factor K	2
Lifetime (years)		25 anni		kWh/year	42000
Installation manual language		English			

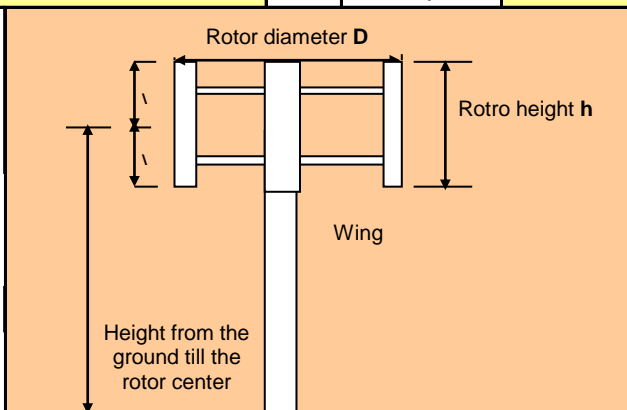

All data are subject to change without notice.



Features Ropatec's small wind turbine vertical axis

Manufacturer		ROPATEC		data AEP	
Model		GIGA STAR		Power curve	
		1		Wind speed (m/s)	Power (W)
Number of installed turbines, in how many countries		800 turbines in 34 countries		1	
Nominal power (KVA)		25KW (max30kW)		2	
Wind speed (m/s)	Cut-in	3-4m/s		3	0
	Nominal	11,8		4	808
	Cut-out	20		5	1654
	Wind class IEC61400	class 3 (peaks of 53m/s)		6	3032
Axis		Vertical axis		7	5042
Pale aerogeneratore	Number	3		8	7526
	Material	iron, fiberglass and carbon fiber		9	10716
Rotore diameter D (m)		10m		10	14700
Rotor height h (m), for vertical axis wind turbines		8m		11	19566
Autonomus start up		No, through inverter ca. 3,5m/s		12	22483
Controlled power output		Power curve, mppt system		13	25517
Rotation velocity (rpm)	Minimum	1		14	28729
	Nominal	50		15	30000
	Maximum	90		16	30000
Gearbox		absent		17	30000
Generator type		PMG - permanent magnet generator		18	30000
Noise level	Level (dBA)	ca. 43dB		19	30000
	At which wind speed (m/s)	10m/s		20	30000
	Distance from the generator (m)	20m		21	
Wind turbine support	Height H center from foundation (m)	Lowest	15m	Possible AEP	
		Usual	24,75m	Speed (m/s)	5,5
		Max	24,75m	Factor K	2
	Type	Self carrying structure	self carrying	kWh/year	37400
Lattice tower		on request	Speed (m/s)	6	
Weights	Turbine (without mast)	2700kg		Factor K	2
	Weight of the carrying structure	3600kg/24m		kWh/year	47000
Platform		is needed		Speed (m/s)	7
Installation area		Urban / suburban		Factor K	2
Lifetime (years)		25 anni		kWh/year	66600
Installation manual language		English			

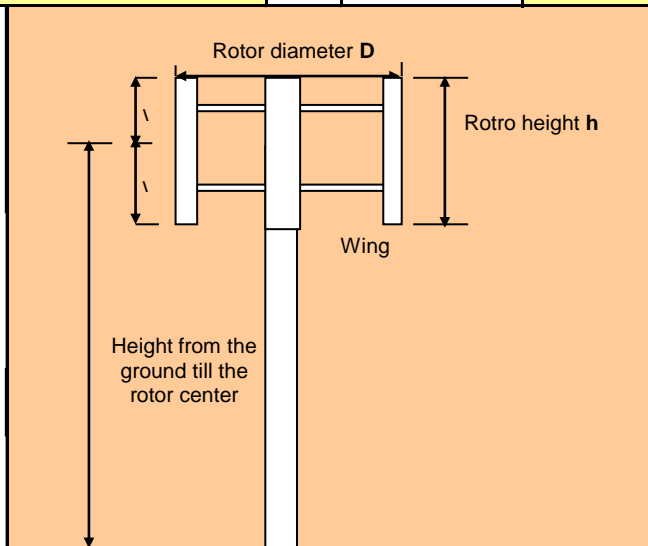
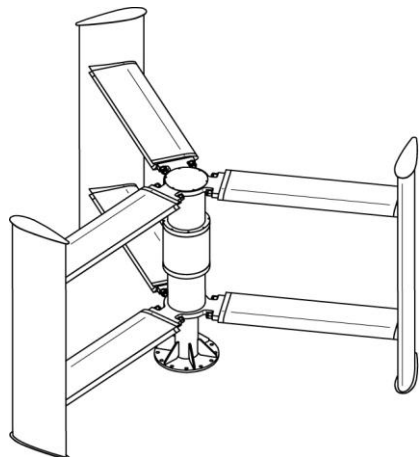

All data are subject to change without notice.